



AND



Station Descriptions

19 Dec 2025

www.aj4co.org

Dave Typinski

CONTENTS

AJ4CO Observatory Outline	1
TFD Array Schematic	4
TFD Array Feed Losses	5
TFD Array Element S_{11} and Pattern	6
Antenna Test Range Feed Schematic	7
RF Surge Suppressors	8
Antenna Feed Control	9
Receivers	10
Calibration Temperatures	11
Power Distribution	13
Ethernet Diagram	14
TFD Array Beam Steering	15
Terrestrial Beam Heading Map	21
Magnetic Declination	22
Facility Layout	23
AJ4CO Oak Lane Station Documentation	24
AJ4CO Locations Within North America	31



26211 W US Hwy 27
PO Box 2423
High Springs, FL 32655

Contact: Dave Typinski
davetyp@typnet.net
(386)344-3166

OBSERVATORY OUTLINE

Location

29° 50' 13" N 29.8369° N EL89qu
82° 37' 17" W 82.6214° W
53 ft (16 m) MSL

Antennas

TFD Array

Two square arrays on a NS line, eight 30-foot TFD elements, beam steering in 5° increments NS and 15° increments EW.

16 MHz HPBW at zenith: 18° NS x 40° EW

20 MHz HPBW at zenith: 15° NS x 35° EW, D ≈ 14 dBic

24 MHz HPBW at zenith: 12° NS x 30° EW

32 MHz HPBW at zenith: 8° NS x 20° EW

For more about the TFD Array, see: [The DPS and TFD Array](#)

Antenna Test Range

Presently conducting galactic background measurement series with $\frac{1}{2}\lambda$ dipoles.

Receivers

Dual Polarization Spectrograph (DPS)

24 x 7 x 365 unattended operation

16–32 MHz, simultaneous (correlated) RCP and LCP

300 channels per polarization (600 total)

Swept frequency, selectable 7.5, 15, 30, 60 kHz pre-detection BW

~ 6.7 sweeps/sec, integration time = 500 μ s per sample

Frequency resolution = 53 kHz, Δt = 150 ms

For more about the DPS, see: [The DPS and TFD Array](#)

Receivers (cont'd)

Radio Jove Receivers

24 x 7 x 365 unattended operation
~ 20.1 MHz, uncorrelated RCP and LCP
7 kHz RF BW folded via direct conversion into a baseband
3.5 kHz pre-detection audio BW
Integration time = 100 ms per sample
For more about the Jove Receivers, See: [Radio Jove Receiver Manual](#)

Icom R8500 + 10.7 MHz Jove Receiver

7 kHz RF BW folded via direct conversion into a baseband
3.5 kHz pre-detection BW
Integration time = 100 ms per sample

Tunable Wideband Receiver (TWB) Mark III

Attended operation only
Tunable from 16 to 32 MHz, RCP or LCP
2 MHz IF BW direct to high speed digitizer
FFT post-processing, RBW = 4.88 kHz, $\Delta t = 205 \mu\text{s}$
For more about the TWB, see: [The TWB](#)

Icom R75 Receivers 1 & 2

Used for live audio stream and as required for antenna test range operations.

Sensitivity

Formal sensitivity calculations and measurements have not been made. A rough estimate considering only the number of dipoles is a 20 MHz on-axis and at zenith 3σ sensitivity on the order of 100 kJy. All receivers presently in use have noise figures between 6 and 8 dB, making their internal noise of little concern given the modest losses between the TFD array and the receivers and the fact that in the upper HF band, system noise is dominated by the galactic background emission.

Timing

All radio telescope data collection systems use a PC's internal clock to apply timestamps to the data. Each PC runs a Network Time Protocol (NTP) daemon to keep its system clock within a few milliseconds of UTC. The NTP server is a GPS-ntp-pi stand-alone unit using multiple GNSS signals to provide the correct time on the local network. For more information, see: [GPS-NTP Pi](#)
For more information, see: [Meinberg NTP Server](#) and [Meinberg NTP Server Monitor](#)

Calibration

All radio telescope systems are calibrated in terms of antenna temperature using a noise source calibrated against a 5722 noise diode. An automatic calibrator runs a step calibration on all receivers, usually twice per day at ± 3 hours from Jupiter transit. The step cal runs 17 steps each separated by 3 dB. Calibration timing, step duration, and noise temperature varies as required by telescope and test range operations. For more information see: [AJ4CO Automatic Calibrator](#)

Computers

Three identical PCs are used to record data from the receivers. Each has a 2.4 GHz AMD Opteron dual-core processor, 4 GB RAM, and a 1 TB hard drive. All run Windows XP SP3. All are connected to the observatory LAN.

Internet

The observatory has internet access via a 6 Mbps DSL connection. This connection allows the Radio Sky Pipe (RSS) and Radio Sky Spectrograph (RSS) software to serve data to interested remote observers.

Power

The receivers, computers, and network hardware are fed by six 1.5 kVA battery backup units providing at least 15 minutes of power if the AC mains fail.

Operations

Several radio telescopes operate all day, every day (see "Receivers" above). Useful Jupiter observations are made any time Jupiter is within 3 hours of transit, but this is extended to around 4.5 hours when Jupiter's transit elevation is greater than 70° and Jupiter is near opposition.

North

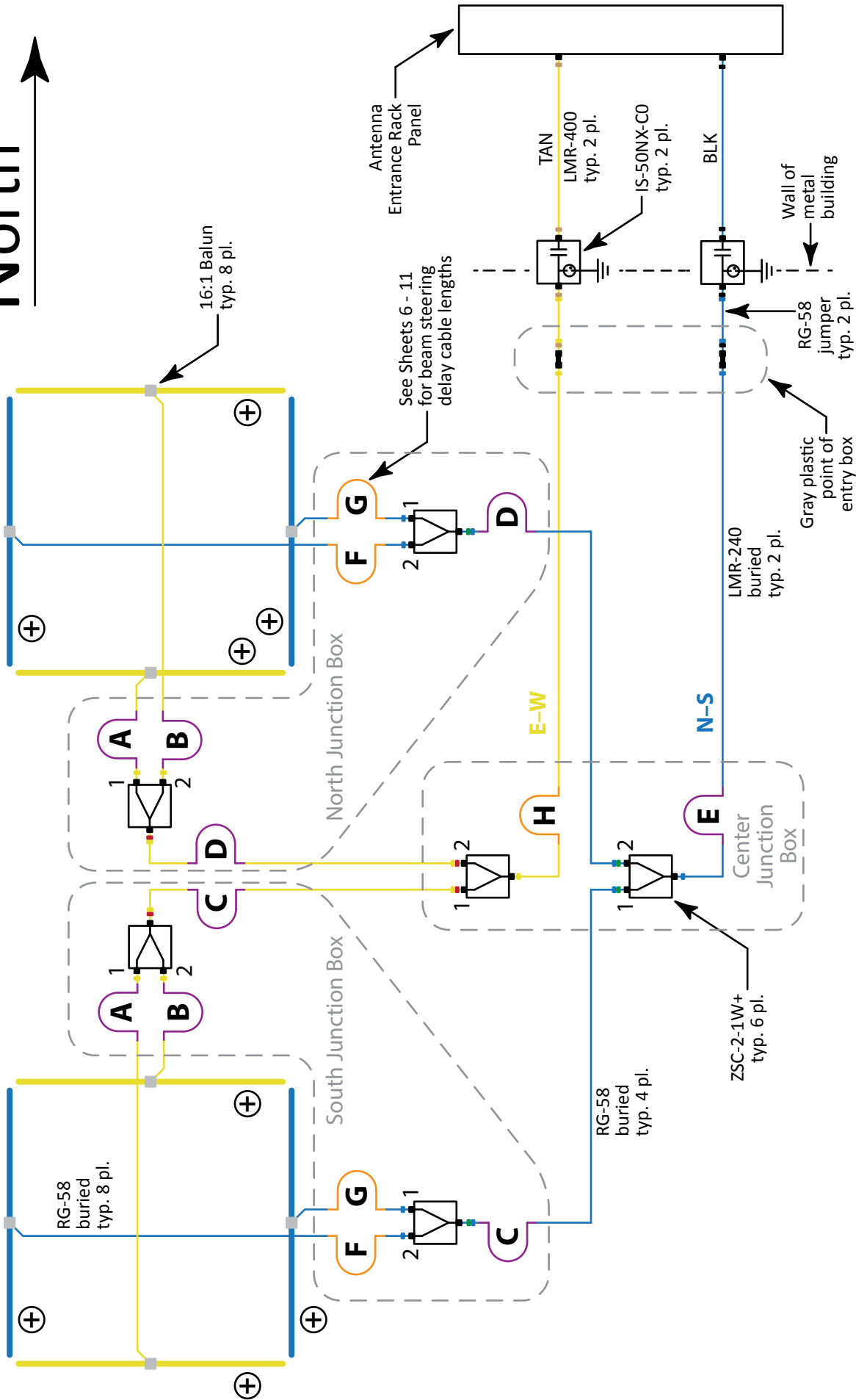

30' terminated folded dipoles, top wire 9'2" height,
8" wire spacing, 32' element spacing,
800 Ω termination resistors, 16:1 baluns.

TFD Array - Electrical



SIZE	DATE	PART NUMBER	REV
A	02 FEB 2020	N/A	B
SCALE	NONE	DRAWN BY	SHEET
		DAVE TYPINSKI	1 OF 1

30' TFD Element Feed Point (Balun Output) Characteristics Plots
 Measured above natural ground (no ground screen).

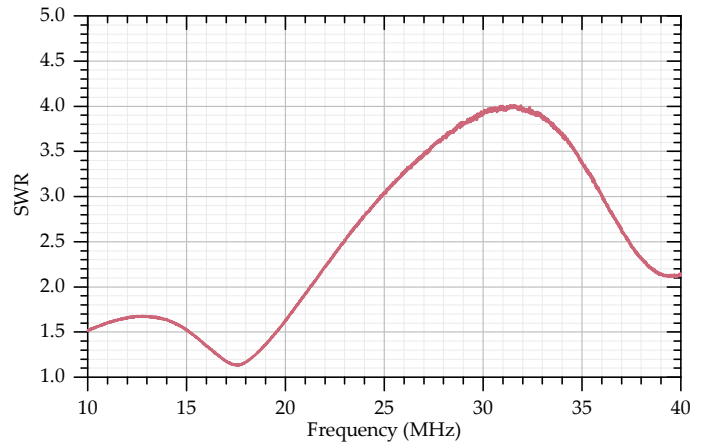
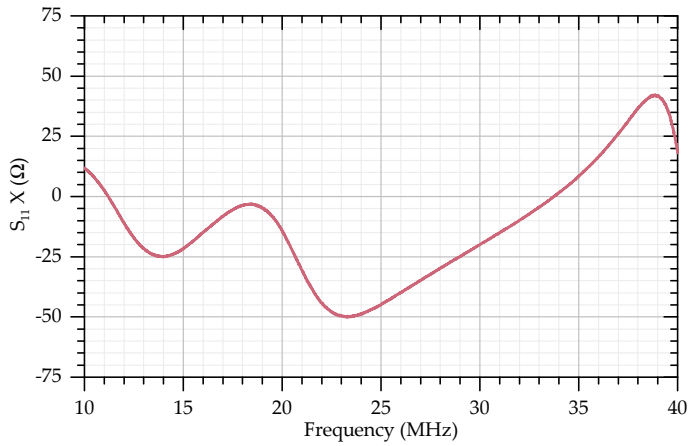
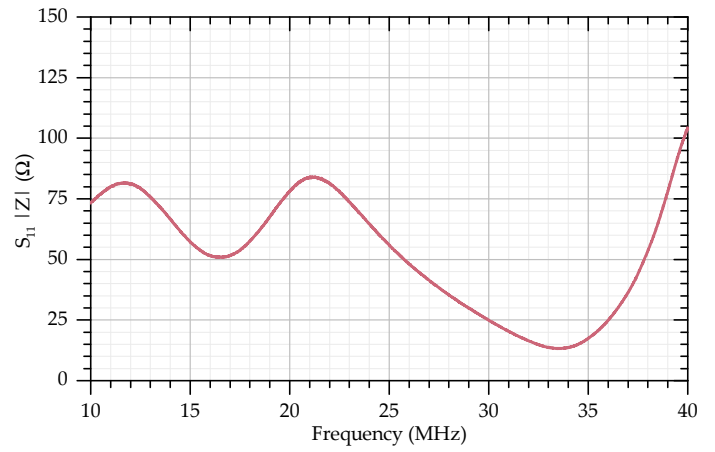
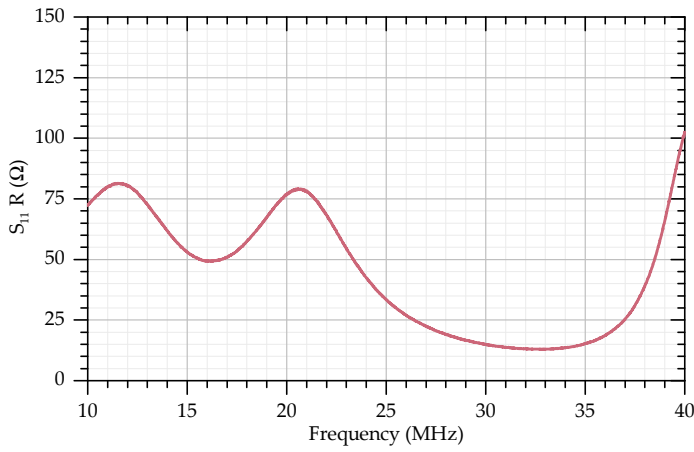

30' TFD 20.1 MHz EZNEC predicted element beam pattern
 Modeled above poor ground. Azimuth pattern at 45° elevation.

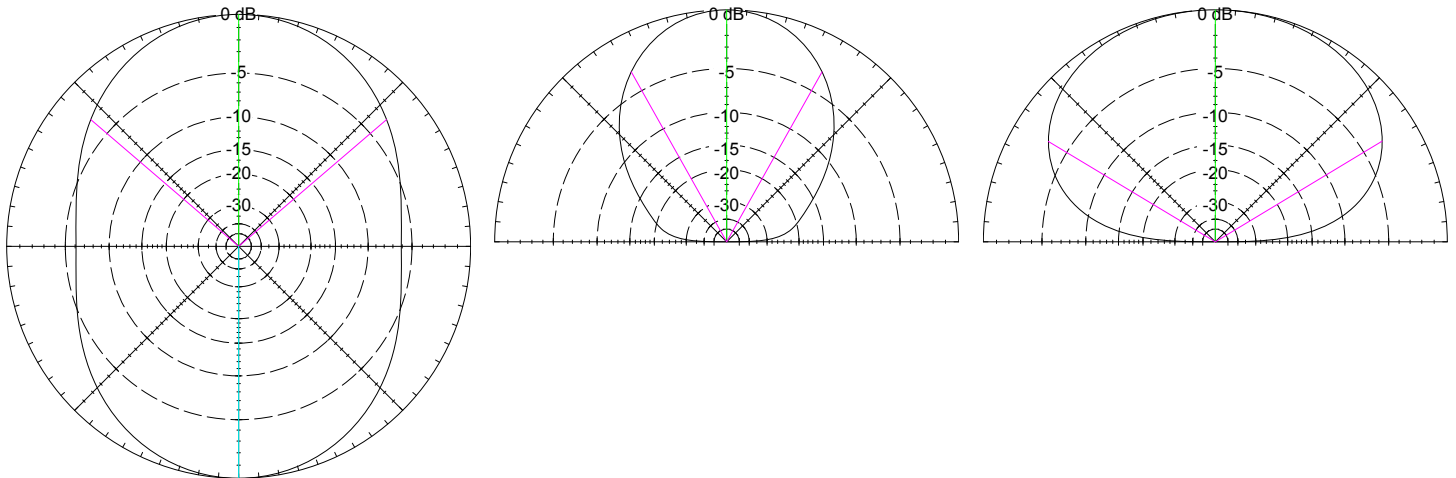

9.6 MHz Dipole
for HAARP lunar
radar experiment

14-bead choke

RED
RG-58

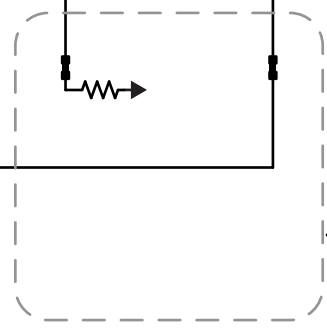

1 1/4" PVC
buried
conduit

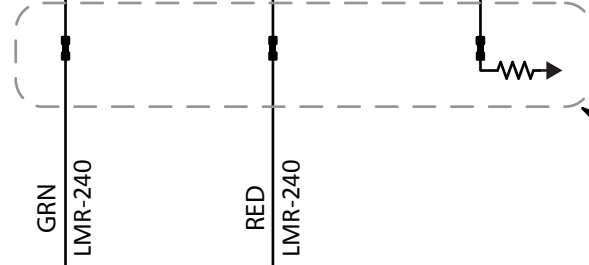

RG-58
jumper
typ. 3 pl.

Gray plastic
point of
entry box

GRN
LMR-240

RED
LMR-240

GRN

Wall of metal
building

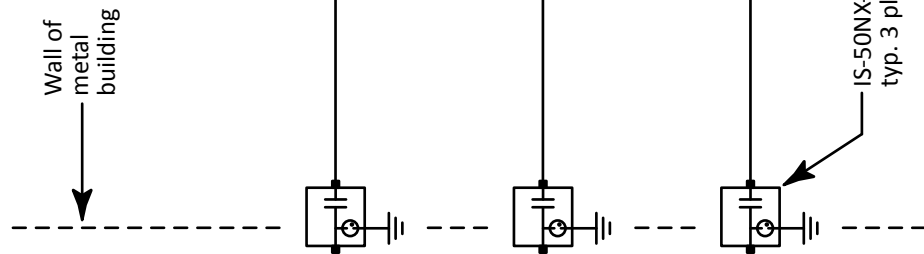

YEL
LMR-400

RED
LMR-400

GRN
LMR-400

IS-50NX-C0
typ. 3 pl.

Antenna
Entrance
Rack Panel



Antenna Test Range - Electrical

SIZE	DATE	PART NUMBER	REV
A	14 JAN 2022	N/A	E
SCALE	NONE	DRAWN BY	SHEET
		DAVE TYPINSKI	1 OF 1

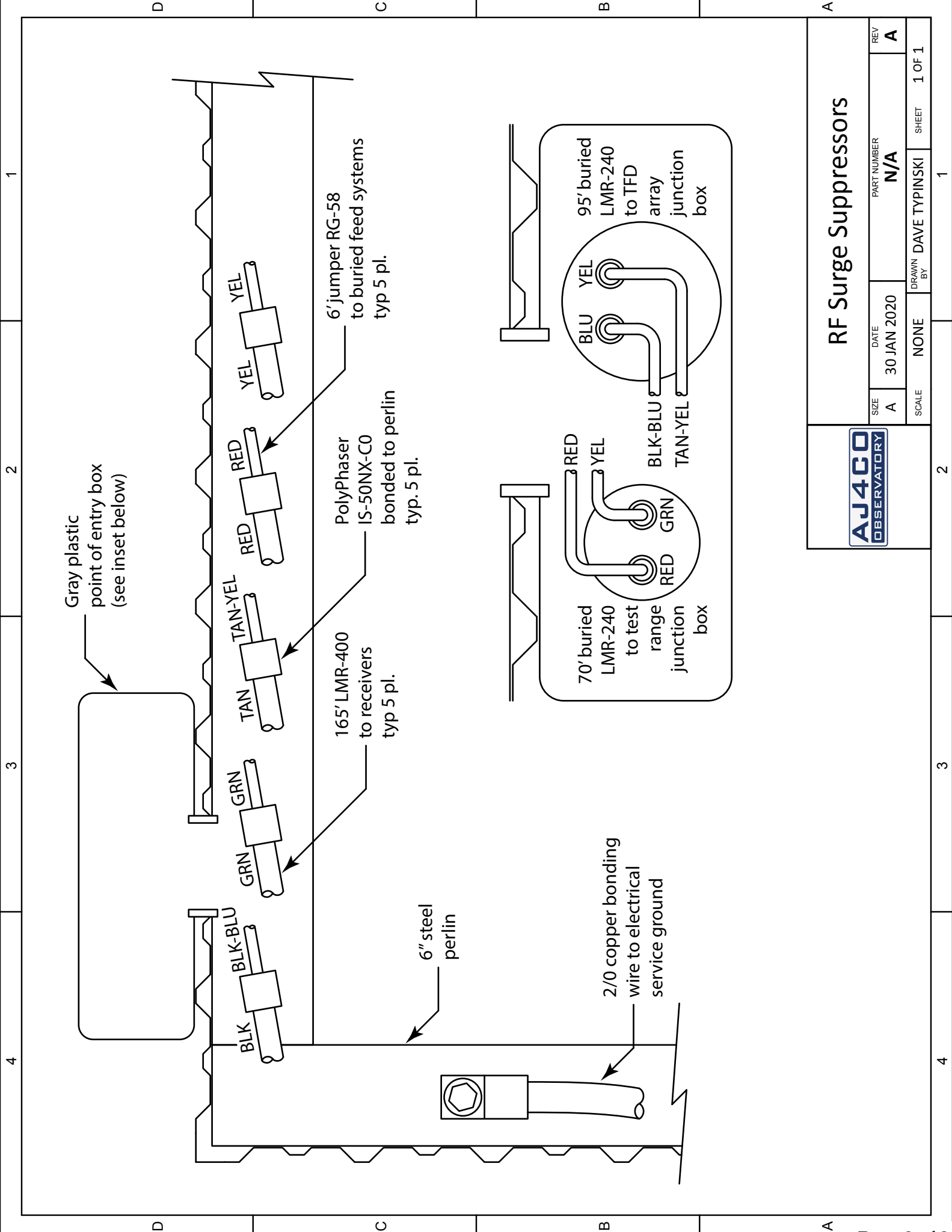

		<h2 style="text-align: center;">RF Surge Suppressors</h2>		REV	A
				DATE	30 JAN 2020
SIZE	A	PART NUMBER	N/A	DRAWN BY	DAVE TYPINSKI
SCALE	NONE	SHEET	1 OF 1		

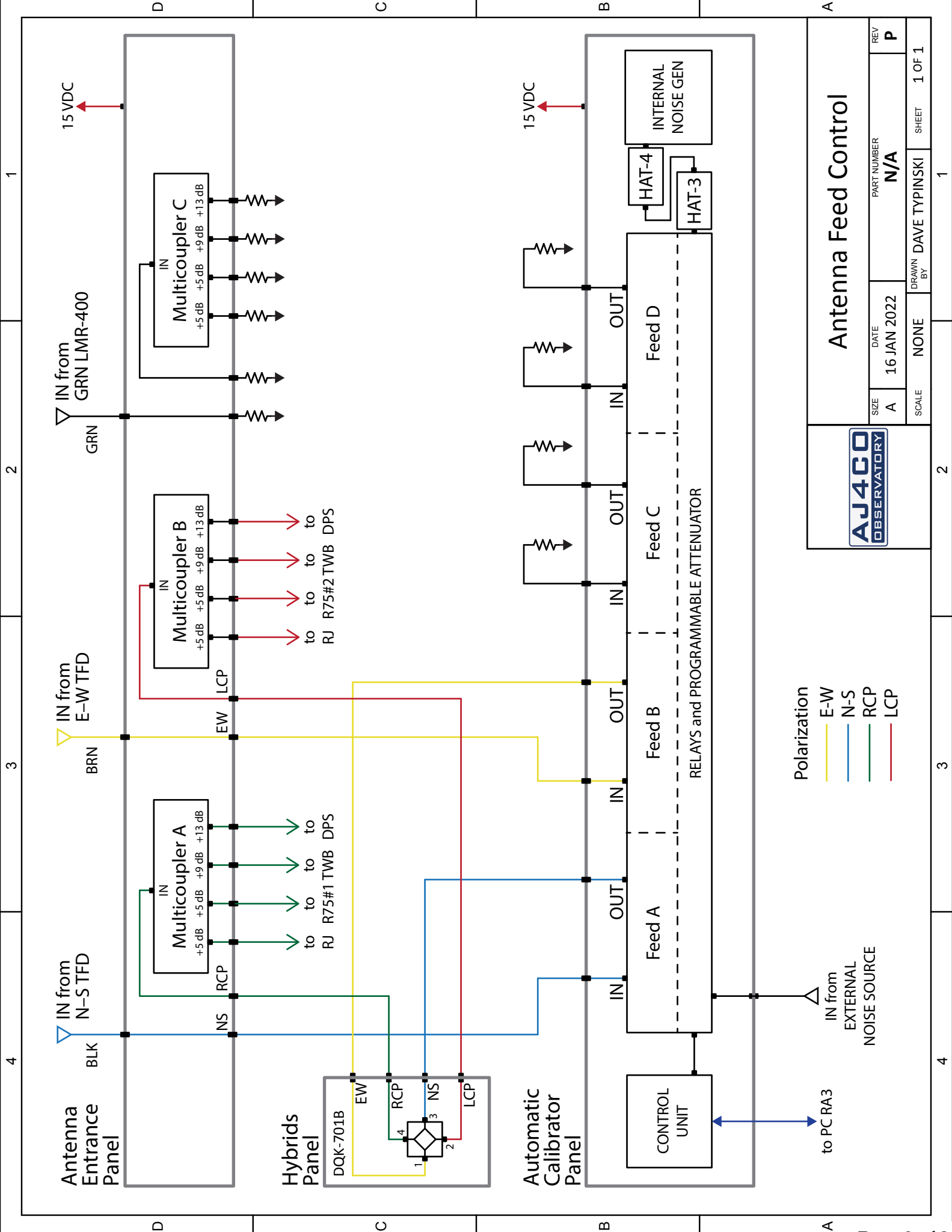

		DATE	16 JAN 2022	PART NUMBER	N/A	REV	P	
		SIZE	A	SCALE	NONE	DRAWN BY	DAVE TYPINSKI	SHEET
Antenna Feed Control								

Polarization

E-W	Yellow
N-S	Blue
RCP	Green
LCP	Red

IN from EXTERNAL NOISE SOURCE

to PC RA3

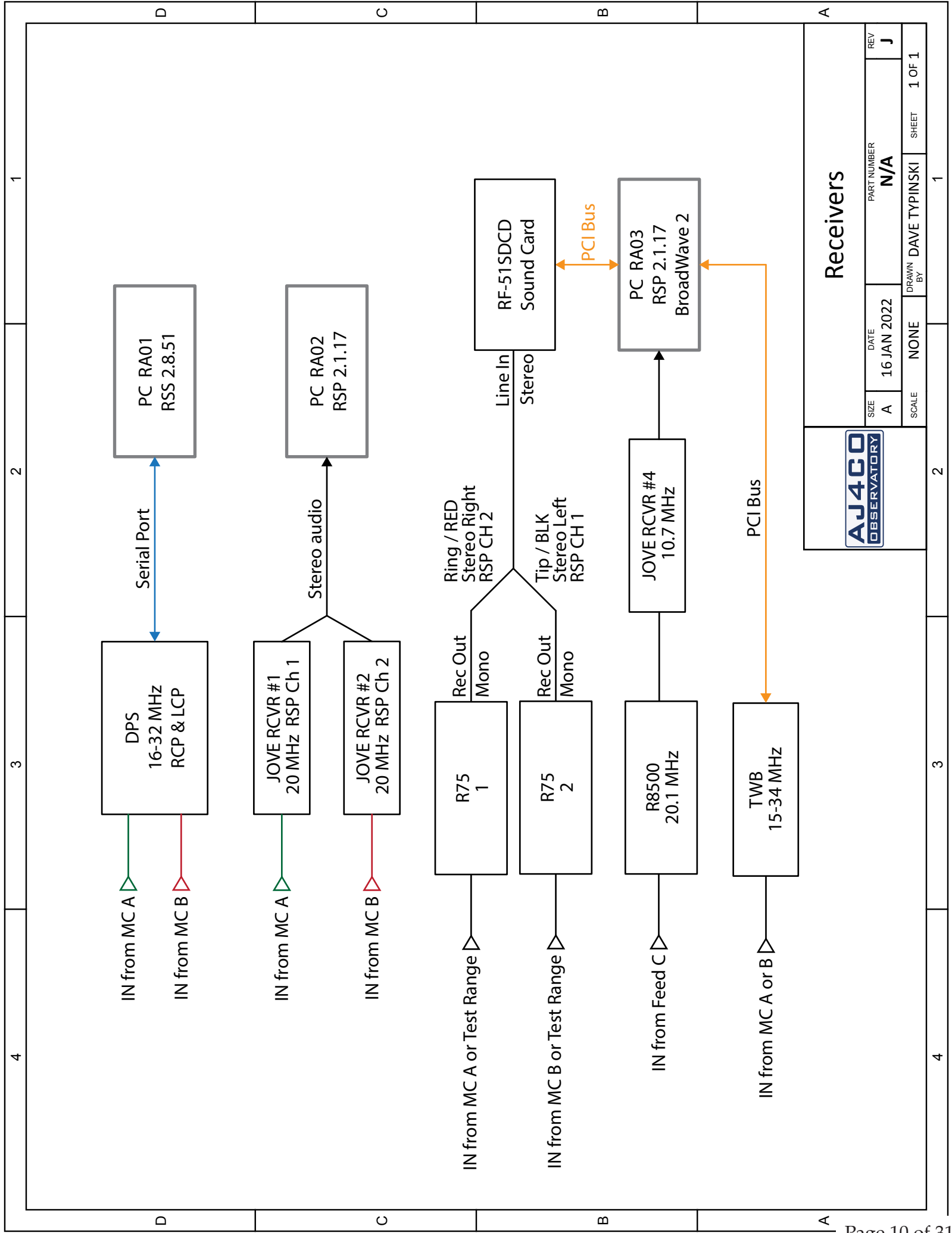

The AJ4CO automatic calibrator is presently modified by the addition of a HAT-4 and a HAT-3 in series at the internal noise generator's output connector. Plots below show the noise temperature and variation at the automatic calibrator front panel connectors (the calibration plane) during the calibrator's 0 dB attenuation step. The internal noise generator was measured at $430 \text{ MK} \pm 0.1 \text{ dB}$ on 05 Jan 2020.

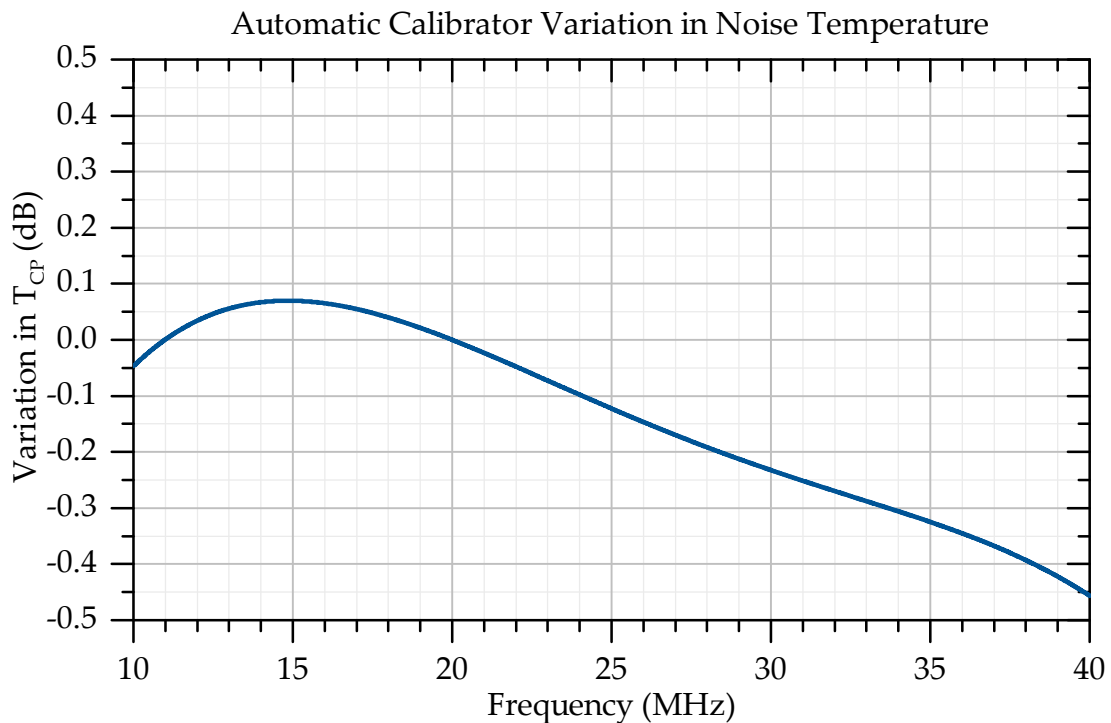
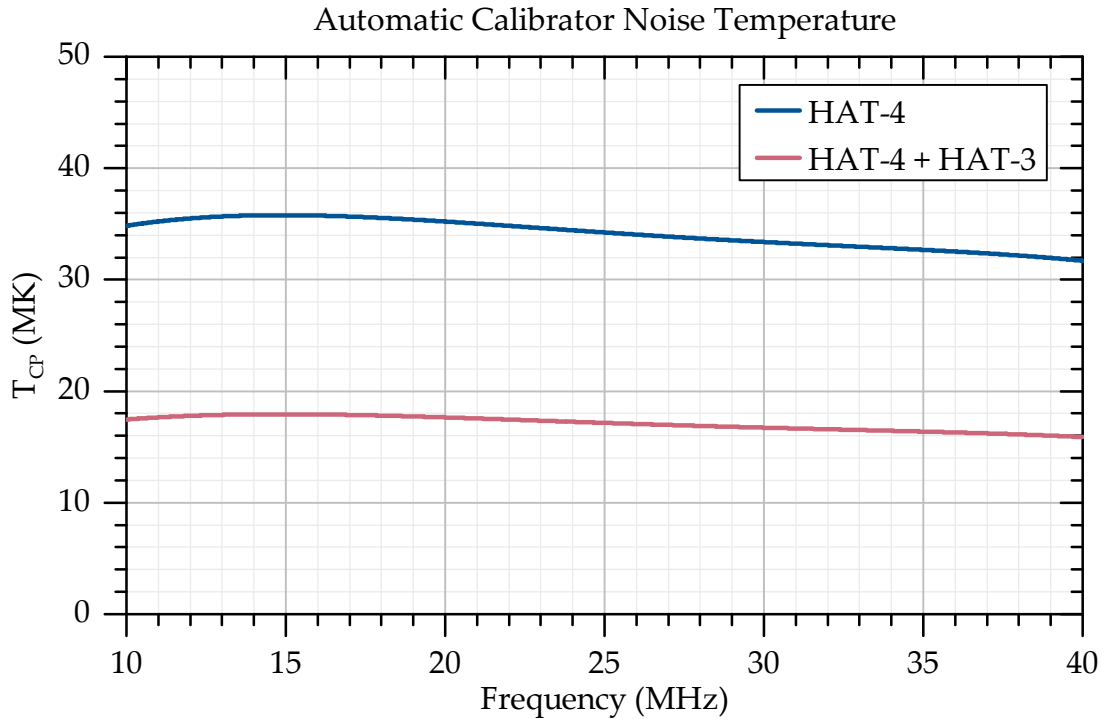

Automatic Calibrator Calibration Plane Noise Temperatures at 20 MHz
 Internal Noise Generator Calibrated Against 5722 on 05 Jan 2020

T₀ (K) 290
Noise Source 20 MHz Temperature (MK) 430
Splitter 20 MHz Loss (dB) 13.4 (6.35 splitter + HAT-4 + HAT-3)

Calibration Plane: CAL relays between Antenna Feeds Entrance and Hybrid Ring Inputs.

Nominal Attn. (dB)	Measured Attn. @ 20 MHz (dB)	Cal Plane Tnoise (K)	Auto Cal Step	Nominal Attn. (dB)	Measured Attn. @ 20 MHz (dB)	Cal Plane Tnoise (K)
0	0.56	17.5 MK	1	0	0.56	17.5 MK
1	1.52	14.0 MK	2	3	3.43	9.03 MK
2	2.56	11.0 MK	3	6	6.47	4.48 MK
4	4.57	6.94 MK	4	9	9.45	2.26 MK
8	8.55	2.78 MK	5	12	12.58	1.10 MK
16	16.58	437 kK	6	15	15.48	563 kK
32	32.50	11.5 kK	7	18	18.55	278 kK
64	64.65	297 K	8	21	21.50	141 kK
			9	24	24.55	70.0 kK
			10	27	27.51	35.6 kK
			11	30	30.58	17.7 kK
			12	33	33.49	9.19 kK
			13	36	36.54	4.70 kK
			14	39	39.55	2.50 kK
			15	42	42.55	1.40 kK
			16	45	45.59	839 K
			17	48	48.55	568 K



Calibration Temperatures

SIZE	DATE	PART NUMBER	REV
A	02 FEB 2020	N/A	E
SCALE	NONE	DRAWN BY	SHEET
		DAVE TYPINSKI	1 OF 1

15 VDC Power Requirement

Equipment	Draw (mA)
Multicouplers	330
DPS Spectro	720
DPS IF Strips	570
Calibrator	980
TWB Rcvr	250
Jove Rcvrs	160
GPS-ntp-pi	120

Total: 3.1 Amps

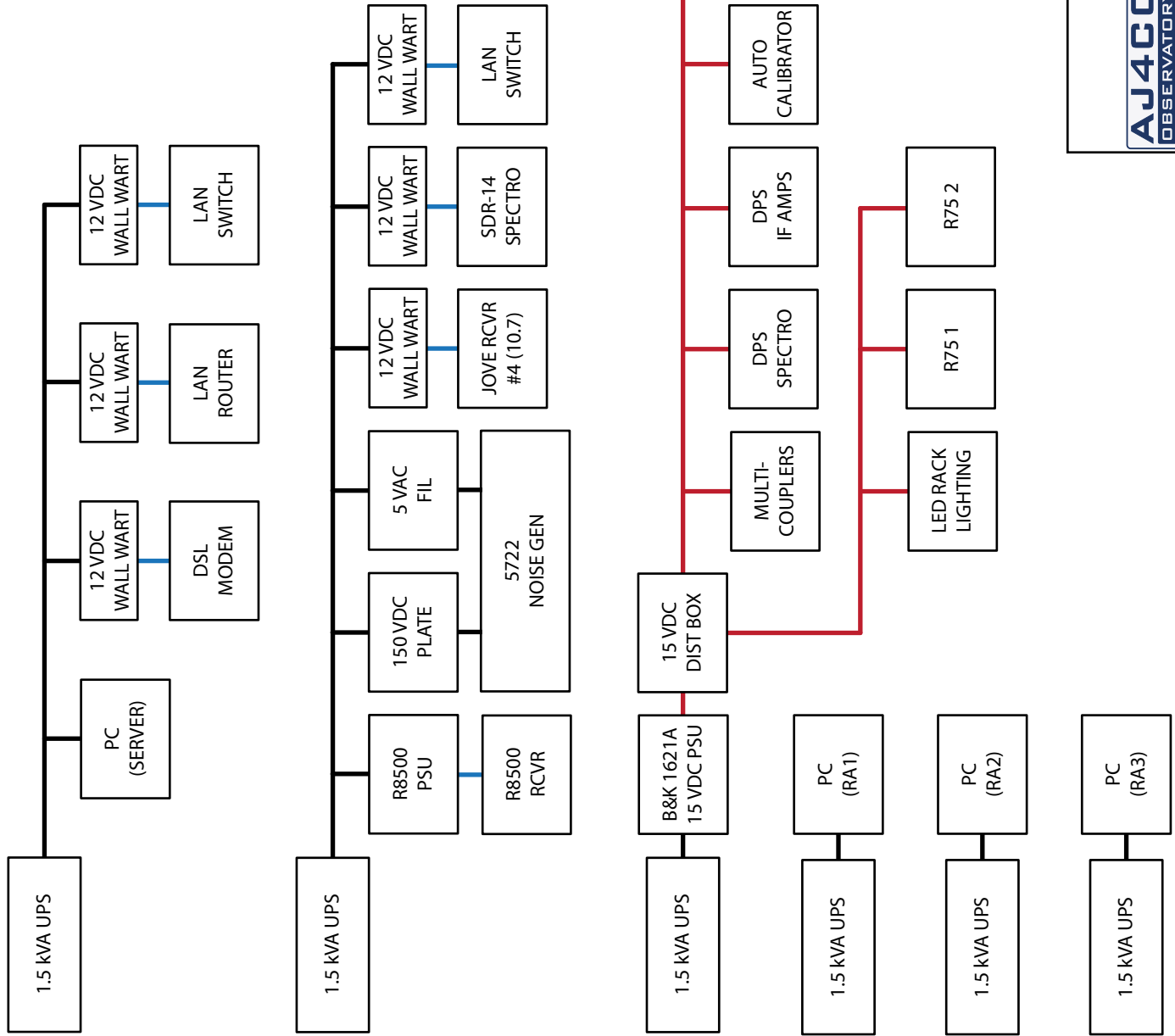

Power Distribution



SIZE	DATE	PART NUMBER	REV
A	29 NOV 2019	N/A	D
SCALE	DRAWN BY	SHEET	1 OF 1
NONE	DAVE TYPINSKI		

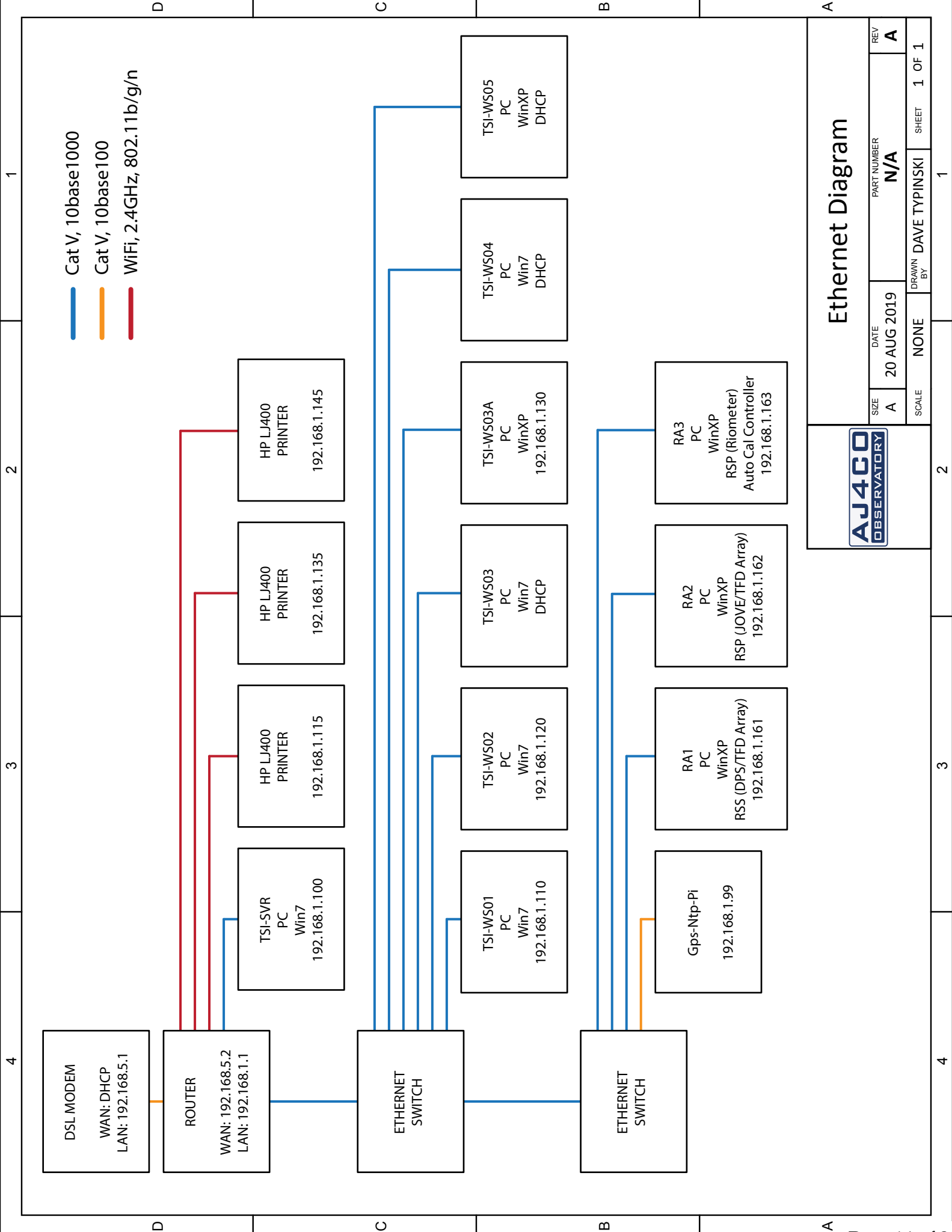

- Cat V, 10base1000
- Cat V, 10base100
- WiFi, 2.4GHz, 802.11b/g/n

Ethernet Diagram



SIZE	DATE	PART NUMBER	REV
A	20 AUG 2019	N/A	A
SCALE	DRAWN BY	SHEET	1 OF 1
NONE	DAVE TYPINSKI		

TFD Array Beam Steering

Time Delay Cable VoP: 66% ray elements N-S baseline spacing (feet): 32
Array elements E-W baseline spacing (feet): 32

N-S Offset (degrees)	E-W Offset (degrees)	Delay Cable Lengths (feet & inches)				AZ (degrees)	EL (degrees)
		A (S) / B (N)	C (S) / D (N)	E F (W) / G (E)	H		
20 N	60 E	7' 2-3/4"	14' 5-1/4"	3' 7-1/4"	18' 3-1/2"	9' 1-3/4"	29
20 N	45 E	7' 2-3/4"	14' 5-1/4"	3' 7-1/4"	14' 11-1/4"	7' 5-1/2"	43
20 N	30 E	7' 2-3/4"	14' 5-1/4"	3' 7-1/4"	10' 6-3/4"	5' 3-1/4"	56
20 N	15 E	7' 2-3/4"	14' 5-1/4"	3' 7-1/4"	5' 5-1/2"	2' 8-3/4"	66
20 N	0	7' 2-3/4"	14' 5-1/4"	3' 7-1/4"	0"	0"	70
20 N	15 W	7' 2-3/4"	14' 5-1/4"	3' 7-1/4"	5' 5-1/2"	2' 8-3/4"	66
20 N	30 W	7' 2-3/4"	14' 5-1/4"	3' 7-1/4"	10' 6-3/4"	5' 3-1/4"	56
20 N	45 W	7' 2-3/4"	14' 5-1/4"	3' 7-1/4"	14' 11-1/4"	7' 5-1/2"	43
20 N	60 W	7' 2-3/4"	14' 5-1/4"	3' 7-1/4"	18' 3-1/2"	9' 1-3/4"	29
15 N	60 E	5' 5-1/2"	10' 11-1/4"	2' 8-3/4"	18' 3-1/2"	9' 1-3/4"	30
15 N	45 E	5' 5-1/2"	10' 11-1/4"	2' 8-3/4"	14' 11-1/4"	7' 5-1/2"	44
15 N	30 E	5' 5-1/2"	10' 11-1/4"	2' 8-3/4"	10' 6-3/4"	5' 3-1/4"	58
15 N	15 E	5' 5-1/2"	10' 11-1/4"	2' 8-3/4"	5' 5-1/2"	2' 8-3/4"	69
15 N	0	5' 5-1/2"	10' 11-1/4"	2' 8-3/4"	0"	0"	75
15 N	15 W	5' 5-1/2"	10' 11-1/4"	2' 8-3/4"	5' 5-1/2"	2' 8-3/4"	69
15 N	30 W	5' 5-1/2"	10' 11-1/4"	2' 8-3/4"	10' 6-3/4"	5' 3-1/4"	58
15 N	45 W	5' 5-1/2"	10' 11-1/4"	2' 8-3/4"	14' 11-1/4"	7' 5-1/2"	44
15 N	60 W	5' 5-1/2"	10' 11-1/4"	2' 8-3/4"	18' 3-1/2"	9' 1-3/4"	30
10 N	60 E	3' 8"	7' 4"	1' 10"	18' 3-1/2"	9' 1-3/4"	30
10 N	45 E	3' 8"	7' 4"	1' 10"	14' 11-1/4"	7' 5-1/2"	45
10 N	30 E	3' 8"	7' 4"	1' 10"	10' 6-3/4"	5' 3-1/4"	59
10 N	15 E	3' 8"	7' 4"	1' 10"	5' 5-1/2"	2' 8-3/4"	72
10 N	0	3' 8"	7' 4"	1' 10"	0"	0"	80
10 N	15 W	3' 8"	7' 4"	1' 10"	5' 5-1/2"	2' 8-3/4"	72
10 N	30 W	3' 8"	7' 4"	1' 10"	10' 6-3/4"	5' 3-1/4"	59
10 N	45 W	3' 8"	7' 4"	1' 10"	14' 11-1/4"	7' 5-1/2"	45
10 N	60 W	3' 8"	7' 4"	1' 10"	18' 3-1/2"	9' 1-3/4"	30

TFD Array Beam Steering



SIZE	DATE	PART NUMBER	REV
A	01 OCT 2014	N/A	A
SCALE	NONE	DRAWN BY	SHEET
		DAVE TYPINSKI	1 OF 6

TFD Array Beam Steering

Time Delay Cable VoP: 66% **Array elements N-S baseline spacing (feet):** 32
Array elements E-W baseline spacing (feet): 32

N-S Offset (degrees)	E-W Offset (degrees)	Delay Cable Lengths (feet & inches)					AZ (degrees)	EL (degrees)
		A (S) / B (N)	C (S) / D (N)	E	F (W) / G (E)	H		
5 N	60 E	1' 10"	3' 8-1/4"	11"	18' 3-1/2"	9' 1-3/4"	87	30
5 N	45 E	1' 10"	3' 8-1/4"	11"	14' 11-1/4"	7' 5-1/2"	85	45
5 N	30 E	1' 10"	3' 8-1/4"	11"	10' 6-3/4"	5' 3-1/4"	81	60
5 N	15 E	1' 10"	3' 8-1/4"	11"	5' 5-1/2"	2' 8-3/4"	72	74
5 N	0	1' 10"	3' 8-1/4"	11"	0"	0"	360	85
5 N	15 W	1' 10"	3' 8-1/4"	11"	5' 5-1/2"	2' 8-3/4"	288	74
5 N	30 W	1' 10"	3' 8-1/4"	11"	10' 6-3/4"	5' 3-1/4"	279	60
5 N	45 W	1' 10"	3' 8-1/4"	11"	14' 11-1/4"	7' 5-1/2"	275	45
5 N	60 W	1' 10"	3' 8-1/4"	11"	18' 3-1/2"	9' 1-3/4"	273	30
0	60 E	0"	0"	0"	18' 3-1/2"	9' 1-3/4"	90	30
0	45 E	0"	0"	0"	14' 11-1/4"	7' 5-1/2"	90	45
0	30 E	0"	0"	0"	10' 6-3/4"	5' 3-1/4"	90	60
0	15 E	0"	0"	0"	5' 5-1/2"	2' 8-3/4"	90	75
0	0	0"	0"	0"	0"	0"	180	90
0	15 W	0"	0"	0"	5' 5-1/2"	2' 8-3/4"	270	75
0	30 W	0"	0"	0"	10' 6-3/4"	5' 3-1/4"	270	60
0	45 W	0"	0"	0"	14' 11-1/4"	7' 5-1/2"	270	45
0	60 W	0"	0"	0"	18' 3-1/2"	9' 1-3/4"	270	30
5 S	60 E	1' 10"	3' 8-1/4"	11"	18' 3-1/2"	9' 1-3/4"	93	30
5 S	45 E	1' 10"	3' 8-1/4"	11"	14' 11-1/4"	7' 5-1/2"	95	45
5 S	30 E	1' 10"	3' 8-1/4"	11"	10' 6-3/4"	5' 3-1/4"	99	60
5 S	15 E	1' 10"	3' 8-1/4"	11"	5' 5-1/2"	2' 8-3/4"	108	74
5 S	0	1' 10"	3' 8-1/4"	11"	0"	0"	180	85
5 S	15 W	1' 10"	3' 8-1/4"	11"	5' 5-1/2"	2' 8-3/4"	252	74
5 S	30 W	1' 10"	3' 8-1/4"	11"	10' 6-3/4"	5' 3-1/4"	261	60
5 S	45 W	1' 10"	3' 8-1/4"	11"	14' 11-1/4"	7' 5-1/2"	265	45
5 S	60 W	1' 10"	3' 8-1/4"	11"	18' 3-1/2"	9' 1-3/4"	267	30

TFD Array Beam Steering

SIZE: A DATE: 01 OCT 2014 PART NUMBER: N/A REV: A
 SCALE: NONE DRAWN BY: DAVE TYPINSKI SHEET: 2 OF 6

TFD Array Beam Steering

Time Delay Cable VoP: 66% **Array elements N-S baseline spacing (feet):** 32
Array elements E-W baseline spacing (feet): 32

N-S Offset (degrees)	E-W Offset (degrees)	Delay Cable Lengths (feet & inches)					AZ (degrees)	EL (degrees)
		A (S) / B (N)	C (S) / D (N)	E	F (W) / G (E)	H		
10 S	60 E	3' 8"	7' 4"	1' 10"	18' 3-1/2"	9' 1-3/4"	96	30
10 S	45 E	3' 8"	7' 4"	1' 10"	14' 11-1/4"	7' 5-1/2"	100	45
10 S	30 E	3' 8"	7' 4"	1' 10"	10' 6-3/4"	5' 3-1/4"	107	59
10 S	15 E	3' 8"	7' 4"	1' 10"	5' 5-1/2"	2' 8-3/4"	123	72
10 S	0	3' 8"	7' 4"	1' 10"	0"	0"	180	80
10 S	15 W	3' 8"	7' 4"	1' 10"	5' 5-1/2"	2' 8-3/4"	237	72
10 S	30 W	3' 8"	7' 4"	1' 10"	10' 6-3/4"	5' 3-1/4"	253	59
10 S	45 W	3' 8"	7' 4"	1' 10"	14' 11-1/4"	7' 5-1/2"	260	45
10 S	60 W	3' 8"	7' 4"	1' 10"	18' 3-1/2"	9' 1-3/4"	264	30
15 S	60 E	5' 5-1/2"	10' 11-1/4"	2' 8-3/4"	18' 3-1/2"	9' 1-3/4"	99	30
15 S	45 E	5' 5-1/2"	10' 11-1/4"	2' 8-3/4"	14' 11-1/4"	7' 5-1/2"	105	44
15 S	30 E	5' 5-1/2"	10' 11-1/4"	2' 8-3/4"	10' 6-3/4"	5' 3-1/4"	115	58
15 S	15 E	5' 5-1/2"	10' 11-1/4"	2' 8-3/4"	5' 5-1/2"	2' 8-3/4"	135	69
15 S	0	5' 5-1/2"	10' 11-1/4"	2' 8-3/4"	0"	0"	180	75
15 S	15 W	5' 5-1/2"	10' 11-1/4"	2' 8-3/4"	5' 5-1/2"	2' 8-3/4"	225	69
15 S	30 W	5' 5-1/2"	10' 11-1/4"	2' 8-3/4"	10' 6-3/4"	5' 3-1/4"	245	58
15 S	45 W	5' 5-1/2"	10' 11-1/4"	2' 8-3/4"	14' 11-1/4"	7' 5-1/2"	255	44
15 S	60 W	5' 5-1/2"	10' 11-1/4"	2' 8-3/4"	18' 3-1/2"	9' 1-3/4"	261	30
20 S	60 E	7' 2-3/4"	14' 5-1/4"	3' 7-1/4"	18' 3-1/2"	9' 1-3/4"	102	29
20 S	45 E	7' 2-3/4"	14' 5-1/4"	3' 7-1/4"	14' 11-1/4"	7' 5-1/2"	110	43
20 S	30 E	7' 2-3/4"	14' 5-1/4"	3' 7-1/4"	10' 6-3/4"	5' 3-1/4"	122	56
20 S	15 E	7' 2-3/4"	14' 5-1/4"	3' 7-1/4"	5' 5-1/2"	2' 8-3/4"	144	66
20 S	0	7' 2-3/4"	14' 5-1/4"	3' 7-1/4"	0"	0"	180	70
20 S	15 W	7' 2-3/4"	14' 5-1/4"	3' 7-1/4"	5' 5-1/2"	2' 8-3/4"	216	66
20 S	30 W	7' 2-3/4"	14' 5-1/4"	3' 7-1/4"	10' 6-3/4"	5' 3-1/4"	238	56
20 S	45 W	7' 2-3/4"	14' 5-1/4"	3' 7-1/4"	14' 11-1/4"	7' 5-1/2"	250	43
20 S	60 W	7' 2-3/4"	14' 5-1/4"	3' 7-1/4"	18' 3-1/2"	9' 1-3/4"	258	29

TFD Array Beam Steering

SIZE	DATE	PART NUMBER	REV
A	01 OCT 2014	N/A	A
SCALE	NONE	DRAWN BY	SHEET
		DAVE TYPINSKI	3 OF 6

TFD Array Beam Steering

Time Delay Cable VoP: 66% **Array elements N-S baseline spacing (feet):** 32
Array elements E-W baseline spacing (feet): 32

N-S Offset (degrees)	E-W Offset (degrees)	Delay Cable Lengths (feet & inches)				AZ (degrees)	EL (degrees)	
		A (S) / B (N)	C (S) / D (N)	E	F (W) / G (E)			H
25 S	60 E	8' 11"	17' 10-1/4"	4' 5-1/2"	18' 3-1/2"	9' 1-3/4"	105	29
25 S	45 E	8' 11"	17' 10-1/4"	4' 5-1/2"	14' 11-1/4"	7' 5-1/2"	115	42
25 S	30 E	8' 11"	17' 10-1/4"	4' 5-1/2"	10' 6-3/4"	5' 3-1/4"	129	53
25 S	15 E	8' 11"	17' 10-1/4"	4' 5-1/2"	5' 5-1/2"	2' 8-3/4"	150	62
25 S	0	8' 11"	17' 10-1/4"	4' 5-1/2"	0"	0"	180	65
25 S	15 W	8' 11"	17' 10-1/4"	4' 5-1/2"	5' 5-1/2"	2' 8-3/4"	210	62
25 S	30 W	8' 11"	17' 10-1/4"	4' 5-1/2"	10' 6-3/4"	5' 3-1/4"	231	53
25 S	45 W	8' 11"	17' 10-1/4"	4' 5-1/2"	14' 11-1/4"	7' 5-1/2"	245	42
25 S	60 W	8' 11"	17' 10-1/4"	4' 5-1/2"	18' 3-1/2"	9' 1-3/4"	255	29
30 S	60 E	10' 6-3/4"	21' 1-1/2"	5' 3-1/4"	18' 3-1/2"	9' 1-3/4"	108	29
30 S	45 E	10' 6-3/4"	21' 1-1/2"	5' 3-1/4"	14' 11-1/4"	7' 5-1/2"	120	41
30 S	30 E	10' 6-3/4"	21' 1-1/2"	5' 3-1/4"	10' 6-3/4"	5' 3-1/4"	135	51
30 S	15 E	10' 6-3/4"	21' 1-1/2"	5' 3-1/4"	5' 5-1/2"	2' 8-3/4"	155	58
30 S	0	10' 6-3/4"	21' 1-1/2"	5' 3-1/4"	0"	0"	180	60
30 S	15 W	10' 6-3/4"	21' 1-1/2"	5' 3-1/4"	5' 5-1/2"	2' 8-3/4"	205	58
30 S	30 W	10' 6-3/4"	21' 1-1/2"	5' 3-1/4"	10' 6-3/4"	5' 3-1/4"	225	51
30 S	45 W	10' 6-3/4"	21' 1-1/2"	5' 3-1/4"	14' 11-1/4"	7' 5-1/2"	240	41
30 S	60 W	10' 6-3/4"	21' 1-1/2"	5' 3-1/4"	18' 3-1/2"	9' 1-3/4"	252	29
35 S	60 E	12' 1-1/4"	24' 2-3/4"	6' 0-3/4"	18' 3-1/2"	9' 1-3/4"	112	28
35 S	45 E	12' 1-1/4"	24' 2-3/4"	6' 0-3/4"	14' 11-1/4"	7' 5-1/2"	125	39
35 S	30 E	12' 1-1/4"	24' 2-3/4"	6' 0-3/4"	10' 6-3/4"	5' 3-1/4"	140	48
35 S	15 E	12' 1-1/4"	24' 2-3/4"	6' 0-3/4"	5' 5-1/2"	2' 8-3/4"	159	53
35 S	0	12' 1-1/4"	24' 2-3/4"	6' 0-3/4"	0"	0"	180	55
35 S	15 W	12' 1-1/4"	24' 2-3/4"	6' 0-3/4"	5' 5-1/2"	2' 8-3/4"	201	53
35 S	30 W	12' 1-1/4"	24' 2-3/4"	6' 0-3/4"	10' 6-3/4"	5' 3-1/4"	220	48
35 S	45 W	12' 1-1/4"	24' 2-3/4"	6' 0-3/4"	14' 11-1/4"	7' 5-1/2"	235	39
35 S	60 W	12' 1-1/4"	24' 2-3/4"	6' 0-3/4"	18' 3-1/2"	9' 1-3/4"	248	28



SCALE: NONE

DATE: 01 OCT 2014

PART NUMBER: N/A

DRAWN BY: DAVE TYPINSKI

SHEET: 4 OF 6

TFD Array Beam Steering

TFD Array Beam Steering

Time Delay Cable VoP: 66% **Array elements N-S baseline spacing (feet):** 32
Array elements E-W baseline spacing (feet): 32

N-S Offset (degrees)	E-W Offset (degrees)	Delay Cable Lengths (feet & inches)					AZ (degrees)	EL (degrees)
		A (S) / B (N)	C (S) / D (N)	E	F (W) / G (E)	H		
40 S	60 E	13' 7"	27' 1-3/4"	6' 9-1/2"	18' 3-1/2"	9' 1-3/4"	116	27
40 S	45 E	13' 7"	27' 1-3/4"	6' 9-1/2"	14' 11-1/4"	7' 5-1/2"	130	37
40 S	30 E	13' 7"	27' 1-3/4"	6' 9-1/2"	10' 6-3/4"	5' 3-1/4"	145	44
40 S	15 E	13' 7"	27' 1-3/4"	6' 9-1/2"	5' 5-1/2"	2' 8-3/4"	162	49
40 S	0	13' 7"	27' 1-3/4"	6' 9-1/2"	0"	0"	180	50
40 S	15 W	13' 7"	27' 1-3/4"	6' 9-1/2"	5' 5-1/2"	2' 8-3/4"	198	49
40 S	30 W	13' 7"	27' 1-3/4"	6' 9-1/2"	10' 6-3/4"	5' 3-1/4"	215	44
40 S	45 W	13' 7"	27' 1-3/4"	6' 9-1/2"	14' 11-1/4"	7' 5-1/2"	230	37
40 S	60 W	13' 7"	27' 1-3/4"	6' 9-1/2"	18' 3-1/2"	9' 1-3/4"	244	27
45 S	60 E	14' 11-1/4"	29' 10-1/2"	7' 5-1/2"	18' 3-1/2"	9' 1-3/4"	120	27
45 S	45 E	14' 11-1/4"	29' 10-1/2"	7' 5-1/2"	14' 11-1/4"	7' 5-1/2"	135	35
45 S	30 E	14' 11-1/4"	29' 10-1/2"	7' 5-1/2"	10' 6-3/4"	5' 3-1/4"	150	41
45 S	15 E	14' 11-1/4"	29' 10-1/2"	7' 5-1/2"	5' 5-1/2"	2' 8-3/4"	165	44
45 S	0	14' 11-1/4"	29' 10-1/2"	7' 5-1/2"	0"	0"	180	45
45 S	15 W	14' 11-1/4"	29' 10-1/2"	7' 5-1/2"	5' 5-1/2"	2' 8-3/4"	195	44
45 S	30 W	14' 11-1/4"	29' 10-1/2"	7' 5-1/2"	10' 6-3/4"	5' 3-1/4"	210	41
45 S	45 W	14' 11-1/4"	29' 10-1/2"	7' 5-1/2"	14' 11-1/4"	7' 5-1/2"	225	35
45 S	60 W	14' 11-1/4"	29' 10-1/2"	7' 5-1/2"	18' 3-1/2"	9' 1-3/4"	240	27
50 S	60 E	16' 2-1/4"	32' 4-1/4"	8' 1"	18' 3-1/2"	9' 1-3/4"	125	25
50 S	45 E	16' 2-1/4"	32' 4-1/4"	8' 1"	14' 11-1/4"	7' 5-1/2"	140	33
50 S	30 E	16' 2-1/4"	32' 4-1/4"	8' 1"	10' 6-3/4"	5' 3-1/4"	154	37
50 S	15 E	16' 2-1/4"	32' 4-1/4"	8' 1"	5' 5-1/2"	2' 8-3/4"	167	39
50 S	0	16' 2-1/4"	32' 4-1/4"	8' 1"	0"	0"	180	40
50 S	15 W	16' 2-1/4"	32' 4-1/4"	8' 1"	5' 5-1/2"	2' 8-3/4"	193	39
50 S	30 W	16' 2-1/4"	32' 4-1/4"	8' 1"	10' 6-3/4"	5' 3-1/4"	206	37
50 S	45 W	16' 2-1/4"	32' 4-1/4"	8' 1"	14' 11-1/4"	7' 5-1/2"	220	33
50 S	60 W	16' 2-1/4"	32' 4-1/4"	8' 1"	18' 3-1/2"	9' 1-3/4"	235	25



TFD Array Beam Steering

SIZE	DATE	PART NUMBER	REV
A	01 OCT 2014	N/A	A
SCALE	NONE	DRAWN BY	SHEET
		DAVE TYPINSKI	5 OF 6

TFD Array Beam Steering

Time Delay Cable VoP: 66% **Array elements N-S baseline spacing (feet): 32**
Array elements E-W baseline spacing (feet): 32

N-S Offset (degrees)	E-W Offset (degrees)	Delay Cable Lengths (feet & inches)				AZ (degrees)	EL (degrees)	
		A (S) / B (N)	C (S) / D (N)	E	F (W) / G (E)			
55 S	60 E	17' 3-1/2"	34' 7-1/4"	8' 7-3/4"	18' 3-1/2"	9' 1-3/4"	130	24
55 S	45 E	17' 3-1/2"	34' 7-1/4"	8' 7-3/4"	14' 11-1/4"	7' 5-1/2"	145	30
55 S	30 E	17' 3-1/2"	34' 7-1/4"	8' 7-3/4"	10' 6-3/4"	5' 3-1/4"	158	33
55 S	15 E	17' 3-1/2"	34' 7-1/4"	8' 7-3/4"	5' 5-1/2"	2' 8-3/4"	169	35
55 S	0	17' 3-1/2"	34' 7-1/4"	8' 7-3/4"	0"	0"	180	35
55 S	15 W	17' 3-1/2"	34' 7-1/4"	8' 7-3/4"	5' 5-1/2"	2' 8-3/4"	191	35
55 S	30 W	17' 3-1/2"	34' 7-1/4"	8' 7-3/4"	10' 6-3/4"	5' 3-1/4"	202	33
55 S	45 W	17' 3-1/2"	34' 7-1/4"	8' 7-3/4"	14' 11-1/4"	7' 5-1/2"	215	30
55 S	60 W	17' 3-1/2"	34' 7-1/4"	8' 7-3/4"	18' 3-1/2"	9' 1-3/4"	230	24
60 S	60 E	18' 3-1/2"	36' 7"	9' 1-3/4"	18' 3-1/2"	9' 1-3/4"	135	22
60 S	45 E	18' 3-1/2"	36' 7"	9' 1-3/4"	14' 11-1/4"	7' 5-1/2"	150	27
60 S	30 E	18' 3-1/2"	36' 7"	9' 1-3/4"	10' 6-3/4"	5' 3-1/4"	162	29
60 S	15 E	18' 3-1/2"	36' 7"	9' 1-3/4"	5' 5-1/2"	2' 8-3/4"	171	30
60 S	0	18' 3-1/2"	36' 7"	9' 1-3/4"	0"	0"	180	30
60 S	15 W	18' 3-1/2"	36' 7"	9' 1-3/4"	5' 5-1/2"	2' 8-3/4"	189	30
60 S	30 W	18' 3-1/2"	36' 7"	9' 1-3/4"	10' 6-3/4"	5' 3-1/4"	198	29
60 S	45 W	18' 3-1/2"	36' 7"	9' 1-3/4"	14' 11-1/4"	7' 5-1/2"	210	27
60 S	60 W	18' 3-1/2"	36' 7"	9' 1-3/4"	18' 3-1/2"	9' 1-3/4"	225	22



TFD Array Beam Steering

SIZE	A	DATE	01 OCT 2014	PART NUMBER	N/A	REV	A
SCALE	NONE	DRAWN BY	DAVE TYPINSKI	SHEET	6 OF 6		

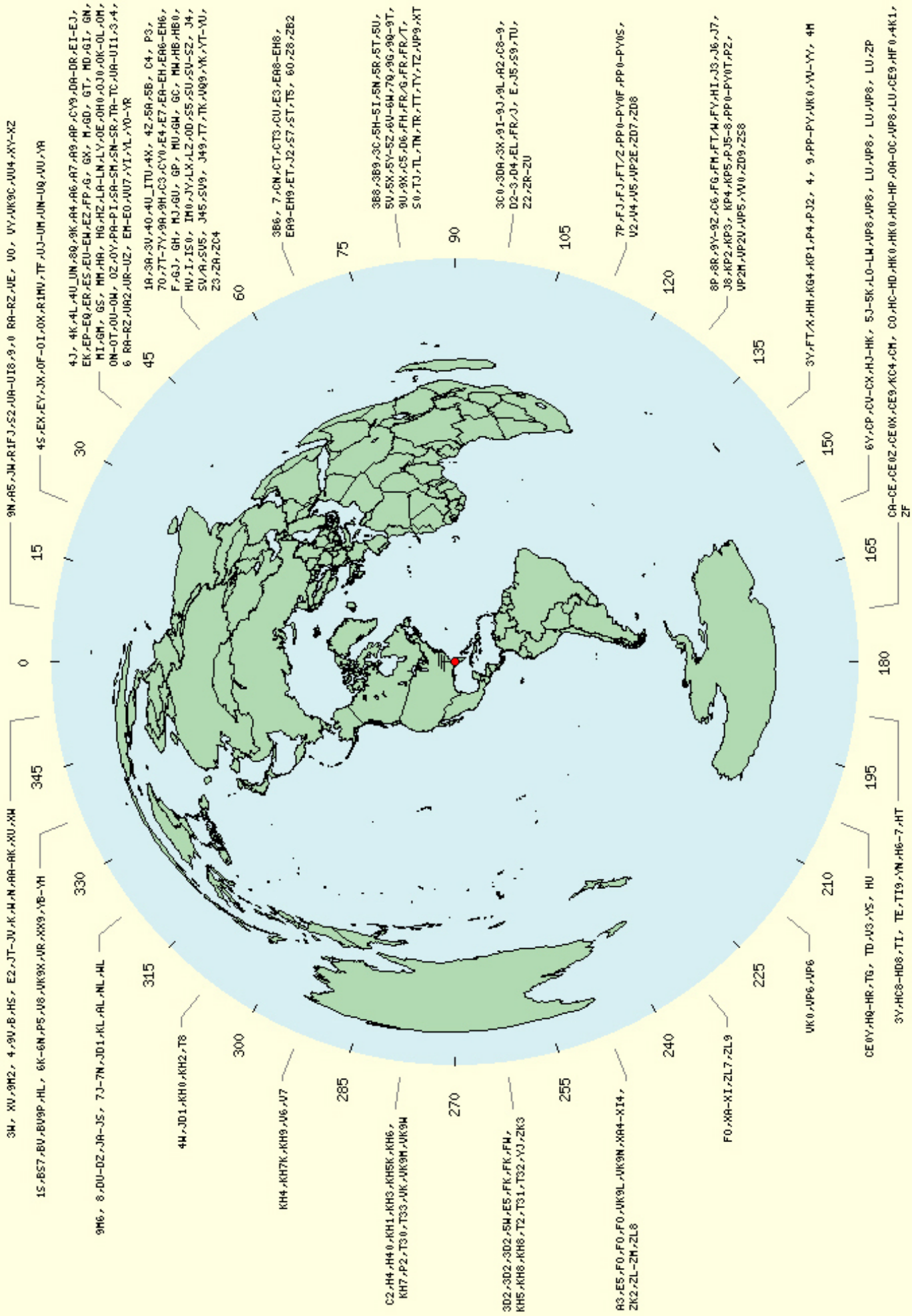

Find the magnetic declination at your location

Sites of Interest

- [Cosmos Plus!](#)
- [Live Meteors](#)
- [Satellite tracking](#)
- [Radio Astronomy](#)

Find your location

City

Enter your city...

Country

USA

State

Search map

[Browse countries](#)

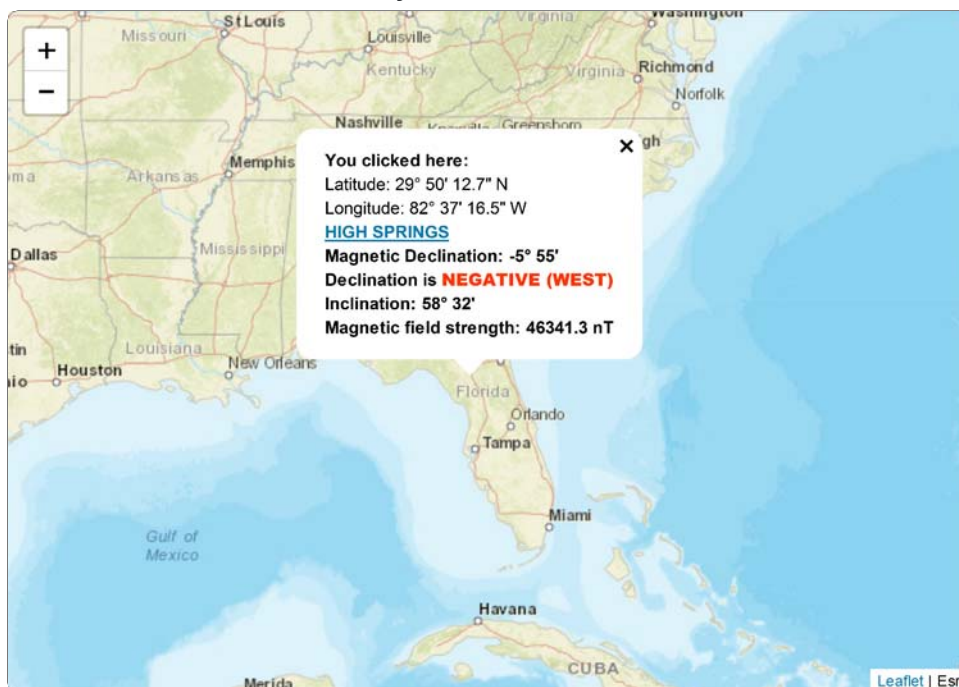

[Share](#)

Copyright ©2020 Magnetic-Declination.com

Magnetic declination is calculated using the World Magnetic Model WMM2020.

Questions? webmaster@magnetic-declination.com

...If the compass at your place is pointing **clockwise** with respect to the True North, declination is **positive** or **EAST**

If the compass at your place is pointing **counter-clockwise** with respect to the True North, declination is **negative** or **WEST**

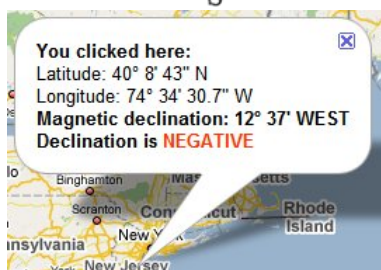
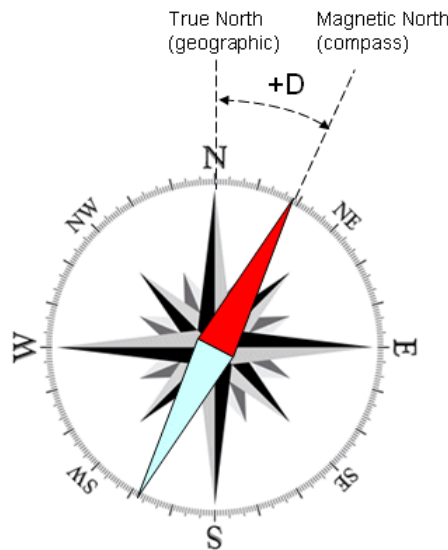
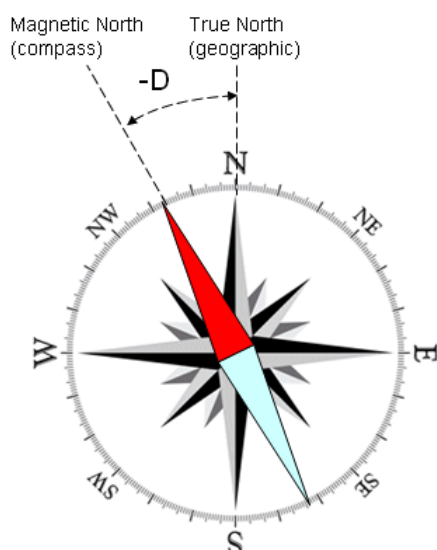

Negative declination (WEST)

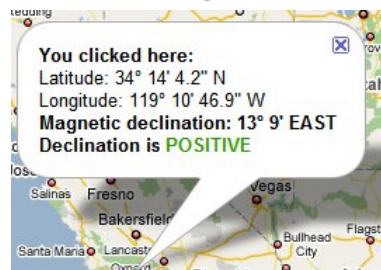

Positive declination (EAST)

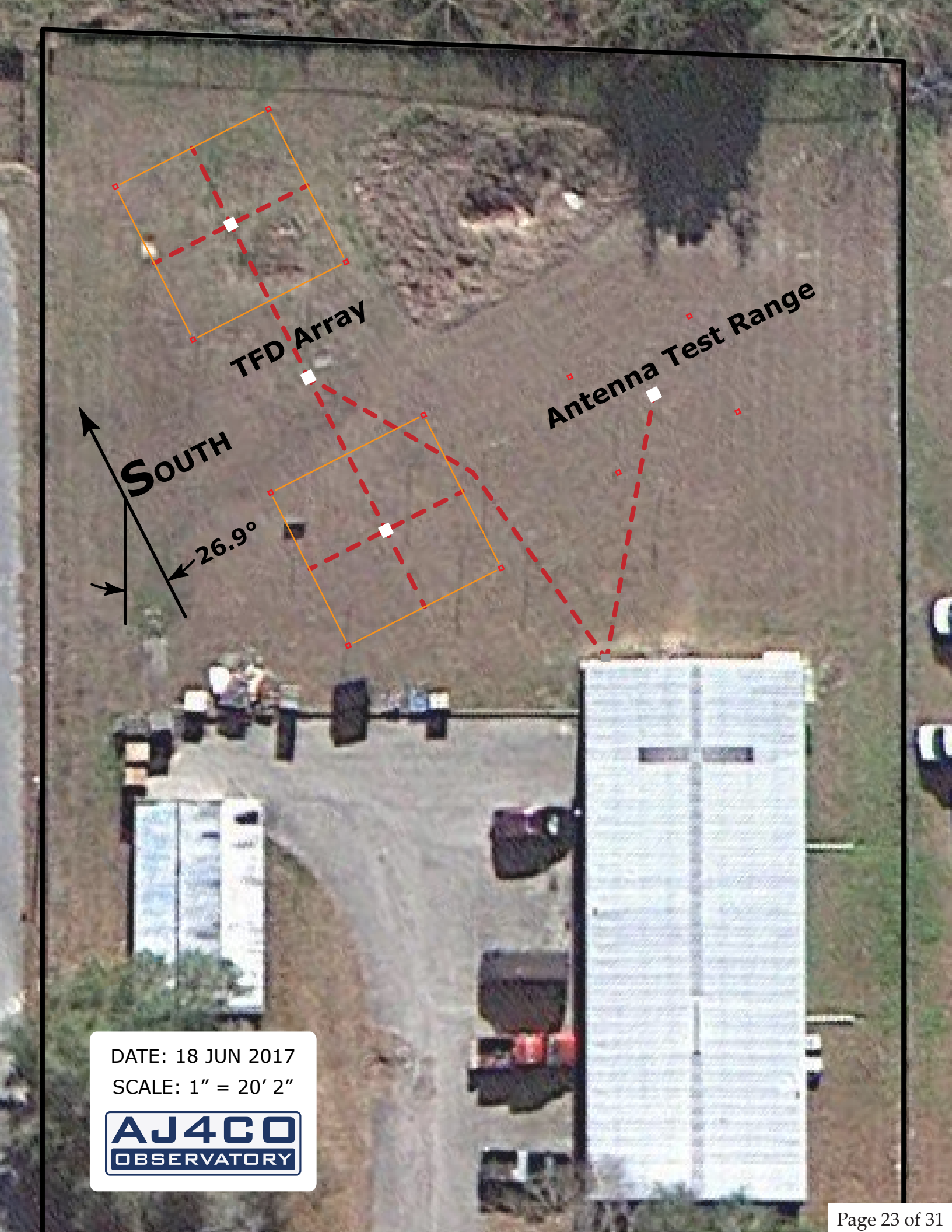

TFD Array

Antenna Test Range

SOUTH

26.9°

DATE: 18 JUN 2017
SCALE: 1" = 20' 2"





Station Description

19 Dec 2025

www.aj4co.org

Dave Typinski

CONTENTS

Observatory Outline	26
TFD Array Schematic	28
TFD Array Feed Losses	29
Antenna Feed Control	30
Location Within North America	31



21762 NW 154 Place
PO Box 2423
High Springs, FL 32655

Contact: Dave Typinski
davetyp@typnet.net
(386)344-3166

OBSERVATORY OUTLINE

Location

29° 47' 53" N 29.7979° N EL89rt
82° 34' 30" W 82.5750° W
89 ft (27 m) MSL

Antennas

2 Element TFD Array

Two 24-foot TFD elements on a NS line, zenith beam steering, EW linear polarization.

16 MHz HPBW at zenith: 64° NS x 64° EW

20 MHz HPBW at zenith: 54° NS x 63° EW, D ≈ 9 dBi, G ≈ 3 dBi

24 MHz HPBW at zenith: 46° NS x 61° EW

32 MHz HPBW at zenith: 36° NS x 58° EW

For more about the TFD Arrays, see [The DPS and TFD Array](#) and [TFD Square Array Manual](#).

Receivers

FSX-1S (AJ4CO Oak Lane)

24 x 7 x 365 unattended operation

15–30 MHz, EW linear polarization

300 channels

Swept frequency, 30 kHz pre-detection BW

~ 6.7 sweeps/sec, integration time = 500 μs per sample

Frequency resolution = 53 kHz, Δt = 150 ms

Radio Jove Receiver

24 x 7 x 365 unattended operation

~ 20.1 MHz, EW linear polarization

7 kHz RF BW folded via direct conversion into a baseband

3.5 kHz pre-detection audio BW

Integration time = 100 ms per sample

For more about the Jove Receivers, See: [Radio Jove Receiver Manual](#)

Sensitivity

Formal sensitivity calculations and measurements have not been made. A rough estimate considering only the number of dipoles is a 20 MHz on-axis and at zenith 3σ sensitivity on the order of 400 kJy. All receivers presently in use have noise figures between 6 and 8 dB, making their internal noise of little concern given the modest losses between the TFD arrays and the receivers and the fact that in the upper HF band, system noise is dominated by the galactic background emission.

Timing

All radio telescope data collection systems use a PC's internal clock to apply timestamps to the data. Each PC runs a Network Time Protocol (NTP) daemon to keep its system clock within a few milliseconds of UTC. The NTP server is a GPS-ntp-pi stand-alone unit using multiple GNSS signals to provide the correct time on the local network.

For more information, see: [GPS-NTP Pi](#)

For more information, see: [Meinberg NTP Server](#) and [Meinberg NTP Server Monitor](#)

Amplitude Calibration

A Radio JOVE HEC Mark II automatic calibrator runs a step calibration on all receivers at 0010 UTC every day. The step cal runs 15 steps each separated by 3 dB. Calibration timing, step duration, and noise temperature are controlled by Radio Sky Spectrograph (RSS) software. For more information see: [HEC Mk II Automatic Calibrator](#).

Computers

Two PCs are used to record data from the receivers. Each PC has a 2.4 GHz AMD Opteron dual-core processor, 4 GB RAM, and a 1 TB hard drive. All run Windows XP SP3, Radio Sky-Pipe (RSP) v 2.1.15, and Radio Sky Spectrograph (RSS) v 2.9.80.

24' terminated folded dipoles, top wire 9'2" height,
8" wire spacing, 26' element spacing,
800 Ω termination resistors, 16:1 baluns.

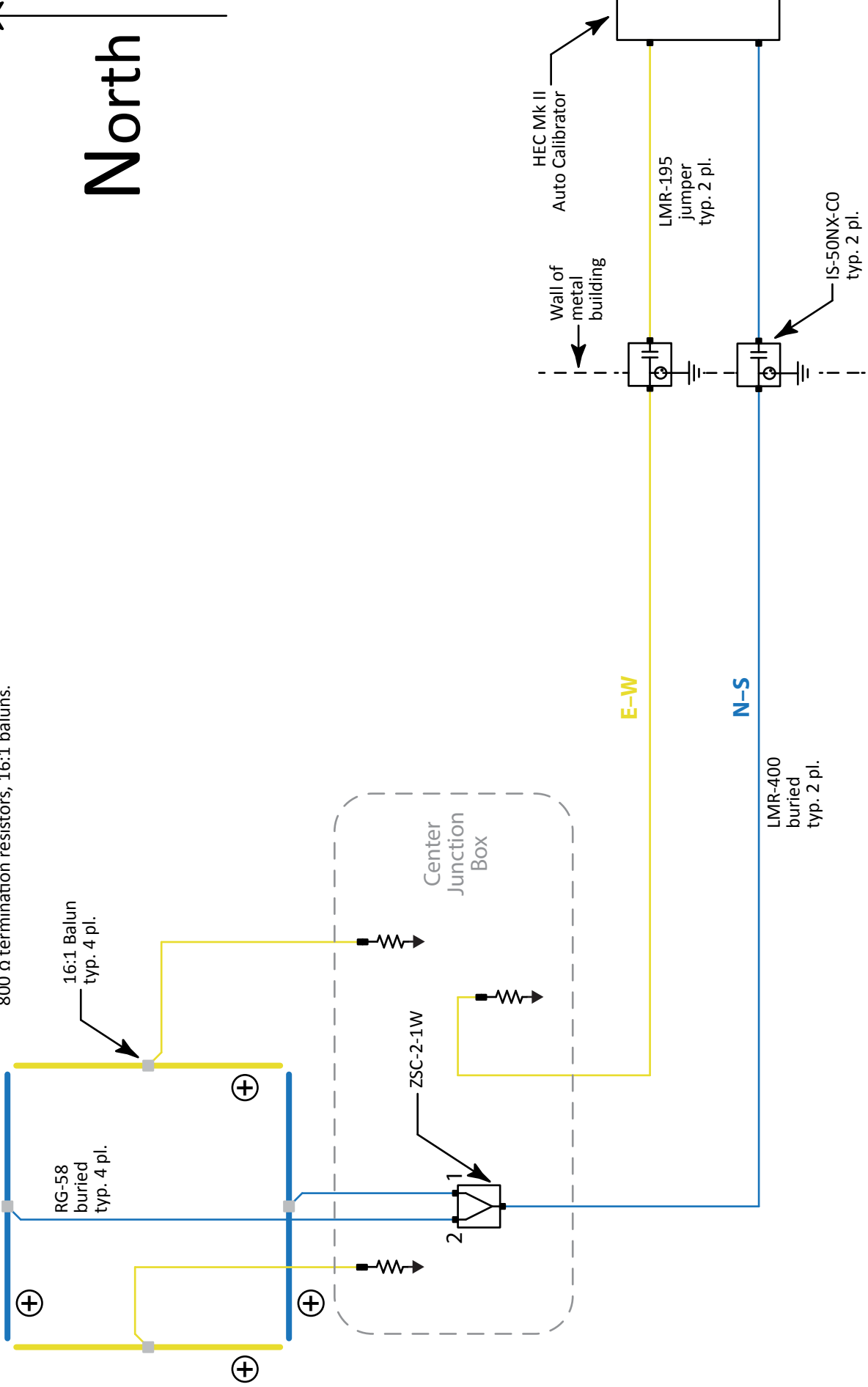
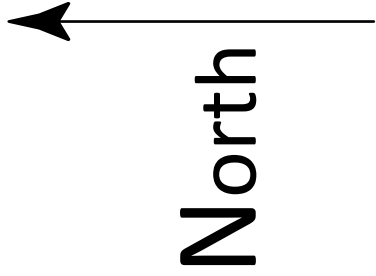

TFD Array - Electrical

SIZE	DATE	PART NUMBER	REV
A	04 AUG 2025	N/A	B
SCALE	NONE	DRAWN BY	SHEET
		DAVE TYPINSKI	1 OF 1

AJ4CO Oak Lane Feed System Losses

Device sweeps performed Apr 2018
 TFD Element Efficiency Measured Jan 2020
 Element feed line and jumper loss sweeps performed July 2025
 Main feed line loss sweeps performed July 2025

Freq (MHz)	Element		Time Delay		Main Feed		PolyPhaser		Jumper		Loss between	
	AN-TFD-24 Element Efficiency	Feed 26' RG-58	Mini-Circuits ZSC-2-1 Combiners	Cables 45S RG-58	260' LMR-400	Arrestor IS-50NX-C0	15' LMR-195	Loss (dB)	Loss (dB)	Loss (dB)	Loss (dB)	TFD balun output and Multicoupler Inputs (CAL PLANE) (dB)
14	-14.7	-0.51	-0.10	0.00	-1.50	-0.01	-0.40	-2.5	-17.2			
16	-11.0	-0.55	-0.10	0.00	-1.58	-0.01	-0.43	-2.7	-13.6			
18	-8.0	-0.57	-0.11	0.00	-1.66	-0.01	-0.45	-2.8	-10.8			
20	-5.8	-0.60	-0.11	0.00	-1.74	-0.01	-0.47	-2.9	-8.7			
22	-4.2	-0.62	-0.11	0.00	-1.81	-0.01	-0.48	-3.0	-7.2			
24	-3.1	-0.64	-0.12	0.00	-1.88	-0.01	-0.50	-3.2	-6.2			
26	-2.5	-0.66	-0.12	0.00	-1.95	-0.01	-0.51	-3.3	-5.8			
28	-2.4	-0.69	-0.12	0.00	-2.01	-0.01	-0.53	-3.4	-5.7			
30	-2.7	-0.71	-0.13	0.00	-2.06	-0.01	-0.55	-3.5	-6.2			
32	-3.5	-0.72	-0.13	0.00	-2.12	-0.01	-0.56	-3.5	-7.0			



TFD Array Feed System Losses

SIZE A	DATE 31 JUL 2025	PART NUMBER N/A	REV B
SCALE NONE	DRAWN BY DAVE TYPINSKI	SHEET 1 OF 1	

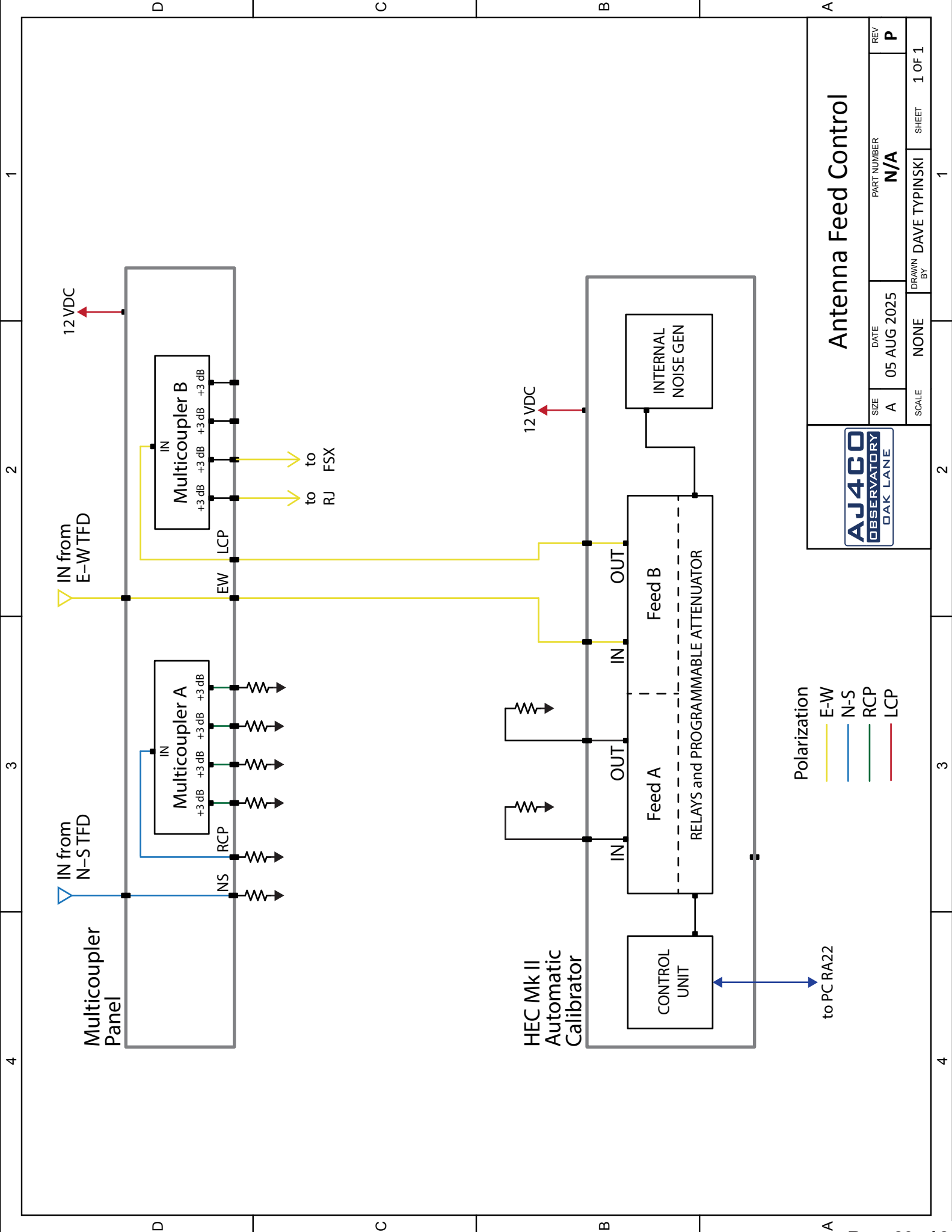

Antenna Feed Control

SIZE	DATE	PART NUMBER	REV
A	05 AUG 2025	N/A	P
SCALE	DRAWN BY	SHEET	1 OF 1
NONE	DAVE TYPINSKI		

Polarization

E-W	—
N-S	—
RCP	—
LCP	—

to PC RA22

AJ400
OBSERVATORY

AJ400
OBSERVATORY
OAK LANE

